



SEMO Výtahy s.r.o.

561 02 Dolní Dobrouč 375

Czech republic

tel: 465 543 412

e-mail: vytahy@semovytahy.cz

servis@semovytahy.cz



Scrap SE 50

Lift machine for food lifts

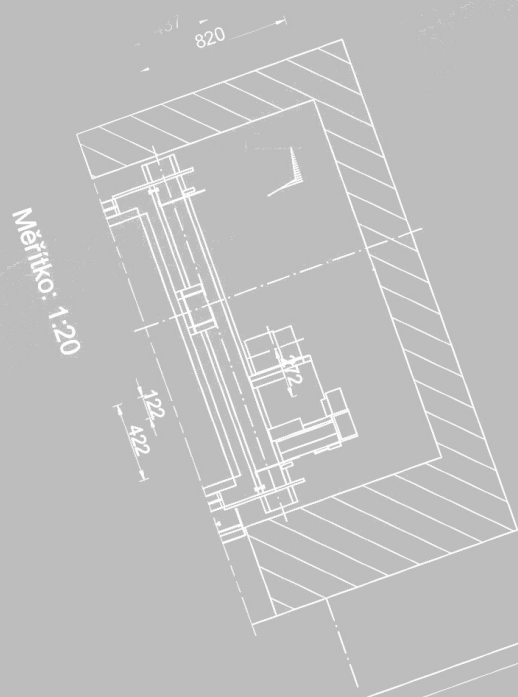
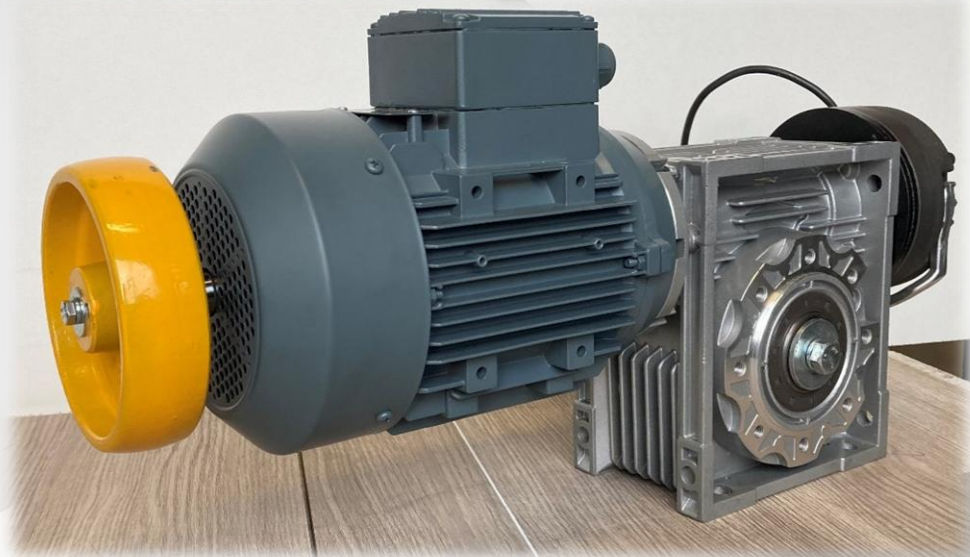

11.11.2020 v.1.0

1273/251:
F6: 0
F7: 0
F8: 0
F9: 0
F12: 0
F13: 0
F12: 0
F13: 0
F12: 0
F13: 0

Výtah LVJT 1273/251
F₄ = F₂ = 518 N
F₅ = 126 N
F₆ = 587 N
F₇ = 518 N

Vodítko kabiny LVJT 1273/251

Měřitko: 1:20

820
120
422

Data sheet of Scrap SE 50

range power:	0,75 kW
poli:	4
frequency:	50 Hz
rpm:	1450
voltage:	3 x 400 V
starting current:	6,2 A
rated current:	1,77 A
machine weight without drum:	24 kg
brake:	207 VDC

Traction system Drum

ratio	Ø drum mm	speed m/s	max. P+Q kg
1/50	210	0,3	120

Ø drum mm	number of ropes	m/ Ø rope	Drum width
210	1	10 / 6-7	125
	2	10 / 6-7	250

Dimensional drawing SCRAP SE 50

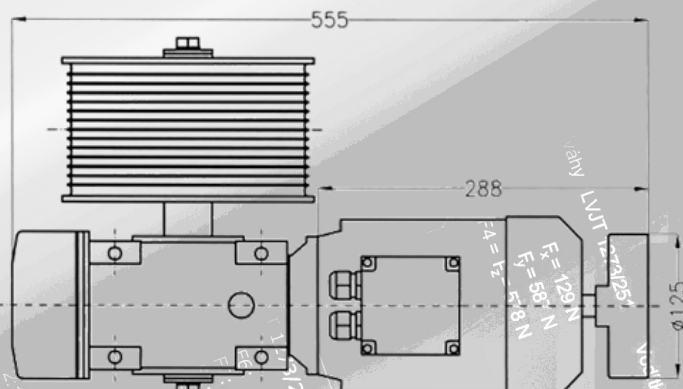
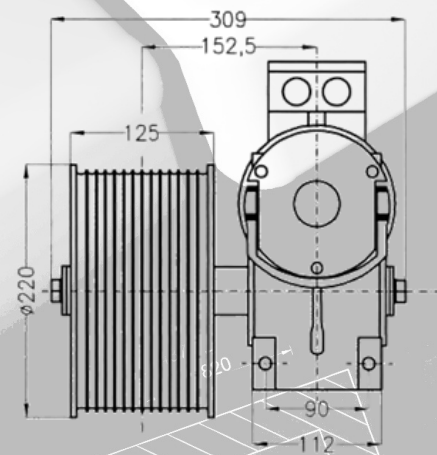
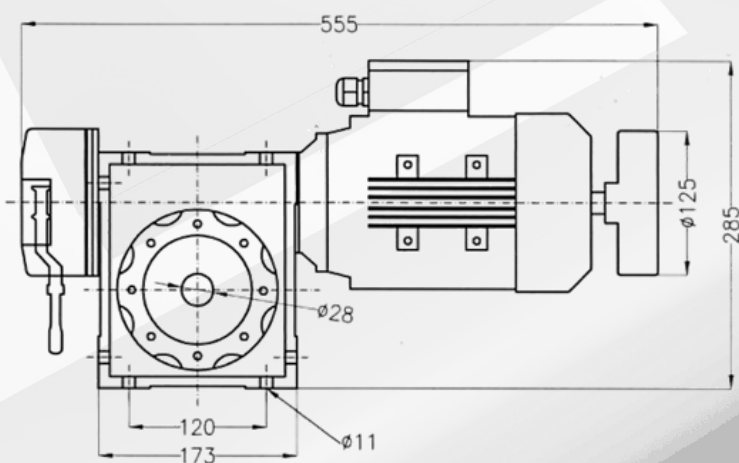

x	x	x	x	x	
Pos.	Název	Kusů	Materiál	Cisté rozměry	Poznámka
561	02 DOLNI DOBROUČ 375				Datum: 4.9.2020
	e.č.0019/6/98/22-V.M.O.G.R.Z/E-V				Kreslil: Vaníček
	SERVIS A MONTÁŽ				Čís. výkresu: 2
	MB 50				
	SCRAP-SE 50				

11.11.2020 v.1.0

Měřtko: 1:20

Měřtko:

LVT 1273/25

1650
1500-2000
1650

F12: 0
F13: 0
F17: 0
F18: 0
F19: 0
F20: 0
F21: 0
F22: 0
F23: 0